

# Davis & Lloyd (ESC), 5' 6" wheelbase Primary Sprung Bogie.

## Safety warning.

This kit is suitable for adults only. There are small and/or sharp components. The castings and recommended solders contain lead. Observe appropriate hygiene precautions; do not eat or handle food without first washing hands. The tools and materials recommended also require the care in handling; protection for the eyes and face (dust mask) must be applied when cutting, soldering, or using a mini-drill.

The bogies are effectively bolster-sprung with a compensating arrangement to mimic the operation of the original. There is sufficient movement in the springing to cope with track irregularities and cant changes in excess of 1mm over the length of the vehicle. The kit is a representation of the 5' 6" Davis & Lloyd (English Steel Casting), complete with the appropriate castings.

### Etched sheet main components:

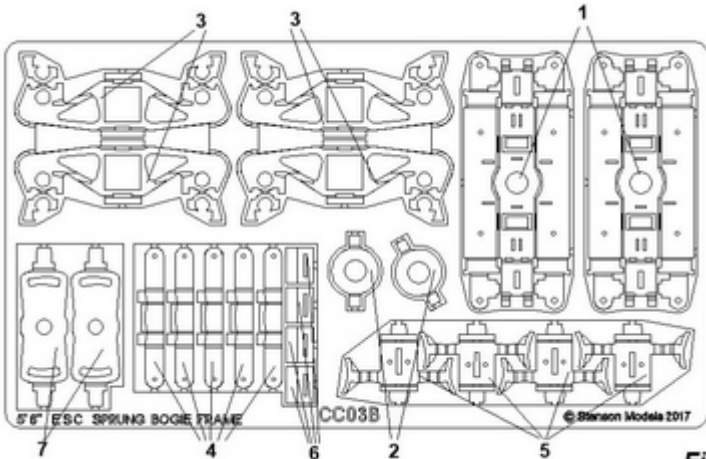

1. Main Bolsters, brakes (2 off)
2. Central pivot bosses (2 off)
3. Side-frame members (4 off)
4. Slide fulcrums (5 off including 1 spare)
5. Vertical slide, rocking plates and inner brakes (4 off)
6. Bolster bearer pads (4 off)
7. Rotation restriction bearers (2 off)

**All 90° folds are with the ½ etched line, ie the groove, in the inside; 180° folds are with the ½ etched line on the outside. All the folds can be performed using a small pair of smooth faced taper nosed pliers, or finger pressure.**

188° solder is recommended throughout, but this is not critical. Slots are generated in the folding operations to locate the springs (Guitar string wire) and it is important not

to flood these with solder. Solder resist is a simple aid to facilitate this; It has been found that a fine black indelible marking pen (eg the type used for marking CD's) is an effective way to achieve this.

### 1. Main bolster box.

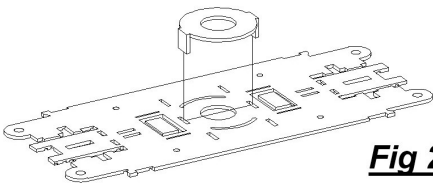

Fig 2

Remove the main bolsters (1) and central pivot bosses (2) from the etched sheet. Fold the two end tags on the pivot bosses at 90° and insert in the slots on the unfolded main bolsters from the plain side (Fig 2); lightly splay the tags outwards from the pivot hole to retain fully in position. Make sure that you have the pivot boss on the surface that will be the outer surface of the box; flux and solder from the tag side. Wash off flux residues, cut off the projecting tags, and sand / file flush.

Fold the 4 outer rounded end flaps 90° and then a further four 90° folds to create partial ends, with the original outer flaps parallel with the sides, pointing inwards; these will provide an internal location for the fulcrum slides. (Fig 3 - 1)

Fold up the 2 sides. The part ends locate into slots inwards from the half-etched line for the outer end flaps. (Fig 3 - 2)

Fold up the outer ends and secure in position with the outer tabs. These tabs are folded over (Each 2 x 90°) into the inside of the bolster box, and aligned in small cut-outs in the inner partial ends. Compress these folds to ensure that the outer ends are hard up against the inner flaps. (Fig 3 - 3)

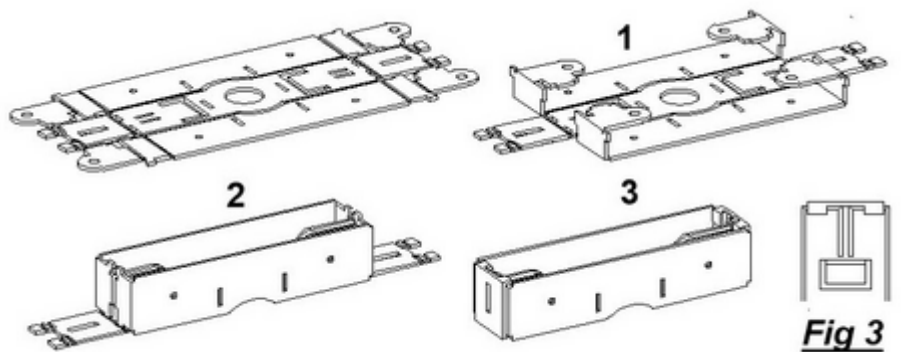

Fig 3

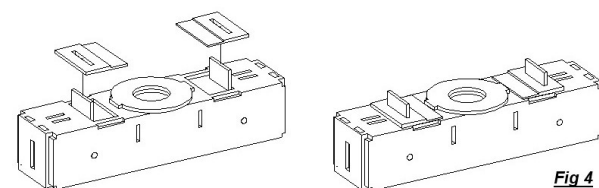

Fig 4

Push out the 2 rotation restriction tabs with 90° folds from inside the formed box. Remove the bolster bearer pads (6) from the etched sheet and slide them down over the rotation restriction tabs; the non-etched surface must be against the bolster and the half-etched part towards the central pivot hole, thus covering the apertures on the top surface of the box. Secure the bolster box by applying flux and solder where the location tabs for the inner ends are exposed on the top (capillary action will draw the solder down between the outer and inner layers); at the same time flux and solder the

bearer pads in position (fig 4). Avoid getting solder on the outer ends of the box and the top face of the bearer plates.

Wash / soak the completed assemblies in very hot water to remove flux residues. Complete the bolsters by polishing the ends to remove any contaminating solder with a fine abrasive stick (600 – 1000grit). These surfaces will be in sliding contact with other components and must be flat, clean, and free of burrs. Check that the stepped end of a pivot bush will sit correctly in the pivot holes; gently open out with a round needle file, or broach if required.

## 2. Side-frame Etches.

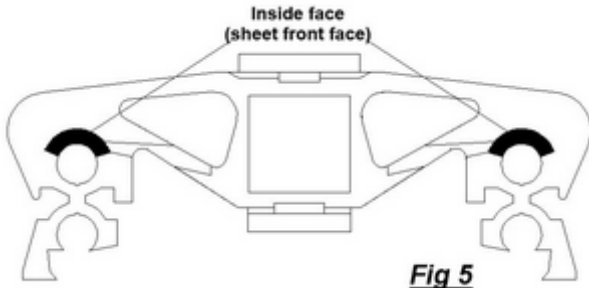

Fold up through 90° the spacing upper and lower flaps for the slide/rocking plates (Folds 1). Fold over the bearing spacers / spring retainers through 180° (Folds 2), and compress with smooth face pliers. Check that the holes are aligned, by gently rotating the shank of a 2mm drill or 2mm rod; it is not necessary to enlarge them (Fig 6).

Insert bearings provided from the back face (through the folded spacers, then the outer frame), and invert the side member; if you position the bearings face down on the work surface, you can press them directly through the aligned spacers and outer frame.

Ensure that the bearings are fully located by pressing down on the outer face of the side-frame (Fig 6), and flux and solder sparingly in position from the plain outer face, on the underside of the bearing. It is not necessary to totally laminate with solder, but only to retain the bearings. Clean off any flux residues in hot water, using a small brush to ensure that the spring slots are thoroughly cleaned.

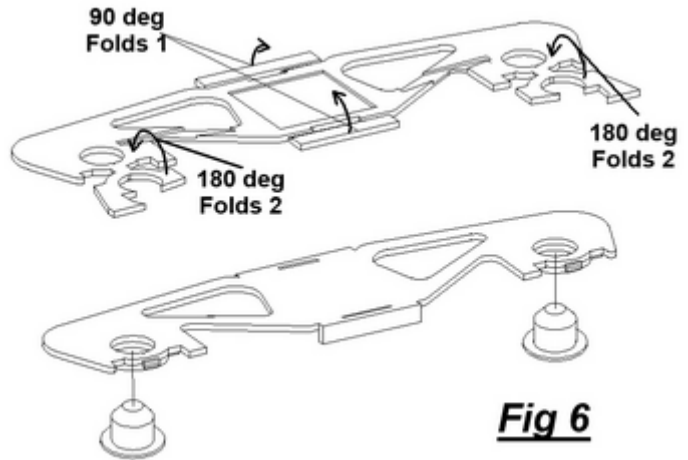

## 3. Slide fulcrums.

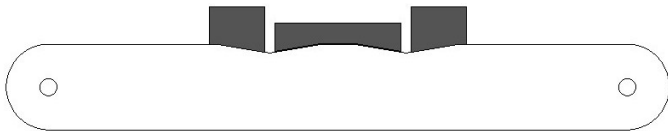

Fig 7

Remove the slide fulcrums (4) from the etched sheet (note that there is 1 spare for this critical component). Apply solder resist (indelible ink marker pen) to the half-etched areas (on the half-etched side) that will form the spring retainer slot (Fig 7). Bend the outer parts through a little over 90° (Folds 1), and then fold backwards through 180° (Folds 2) at the inner etched line. Note that the fulcrum slides are "sided" the upper edge being plain and the lower edge with a half-etched border to create a channel for location of the spring wire. Be careful in handling to ensure this doesn't become distorted, or the spring wire will not fit. (fig 8)

Check that the two legs meet in line at the centre point, and if necessary use side pressure with the pliers to correct. The alignment and the hole clearance can be checked by temporarily threading each of the fulcrums half way along one of the 0.55mm stainless pins; the pin should naturally sit square with the front and top faces of the fulcrum. Compress on a firm surface, by pressing down with the back face of the pliers, so that there is no visible space between the layers. **Take care not to distort the half etched edges that form the slot.** Recheck the alignment of the leg laminates with one of the stainless pins and adjust if required, before finally recompressing the 180° folds.

Grip the ends of the two tongues forming the leg of the **T with the spring slot uppermost (fig 9)**, and ensure that it is square with the top. Still gripping the leg in a compressed position, apply a small amount of flux to the lower edge of the T on the side away from the half etched channel, and solder sparingly to laminate both the outer faces and the T legs. If too much solder is applied, it will risk flooding the spring slot, but the solder resist, and the slot facing upwards should prevent this. It all sounds much more daunting than it is in practise – the key is to control the amount of solder needed, after careful folding and alignment.

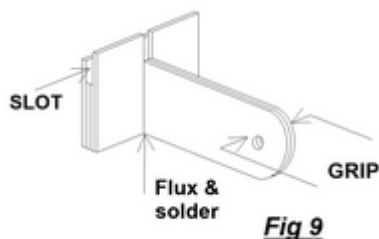

Fig 9

Remove the slide fulcrums (4) from the etched sheet (note that there is 1 spare for this critical component). Apply solder resist (indelible ink marker pen) to the half-etched areas (on the half-etched side) that will form the spring retainer slot (Fig 7).

Bend the outer parts through a little over 90° (Folds 1), and then fold

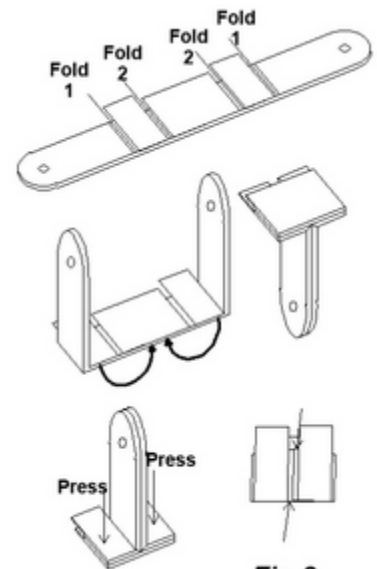

Fig 8

**TIP:** pare off small slivers of solder from the solder stick or wire; these can be selected and picked up by the tip of your soldering iron to limit the quantity that is applied.

Remove any residues of flux by washing in hot water, using a small brush to ensure that the spring slot is thoroughly cleaned. Gently clean up the legs and faces of the T with a fine (600 – 1000grit) abrasive stick to remove any traces of solder, and polish all the faces (not the edges). The faces must be flat, particularly in the area around the sides of the spring slot. Ensure that the half-etched channel on the lower edge is not distorted, and totally free of obstruction. Check that a 0.55mm stainless steel pin will pass in-line through the leg hole. If you need to clear this hole, use a 0.5mm drill in a pin chuck, but take care not to enlarge at this stage.

#### 4. Completion of Side frame Assemblies.

Remove the Slide and rocking plates (5) from the etched sheet. Fold the brake shoes back ( $2 \times 180^\circ$ ) on themselves as a Z format (Fig 10), check the alignment, and compress with pliers. Apply flux and solder sparingly to the edge of the brake shoe fold laminate. It is important that you keep the inner and outer sliding shoe faces of the rocking plate free of solder. Polish with a fine emery stick, if necessary, to remove any solder contamination.

Fold the edges with tabs  $90^\circ$  and check the fit in the back of the side frames; the tabs are of differing widths so that they will only fit one way; the wider tab on the slide plate goes into the lower slot of the side frame. Withdraw the slide plate and insert a fulcrum slide from the back, **with the spring channel at the bottom**, next to the wider tab (Fig 10).

Check that the fulcrum slide moves freely in the slot; If necessary gently relieve the slot over its full length with a piece of 600grit folded abrasive, approximately 2mm wide Refit to the side-frame, push firmly home, and twist the tabs to hold. Again check that the fulcrum slide moves freely in the slot, and finally again check that the spring channel is correctly positioned on the lower side.

Flux and solder the two tabs sparingly. Thoroughly clean/soak in hot water, using a small brush to clean behind the fulcrum slide. Rinse, and dry. Use side cutters to remove the slide and rocking plate tabs, and finish with a fine flat needle file or abrasive stick.

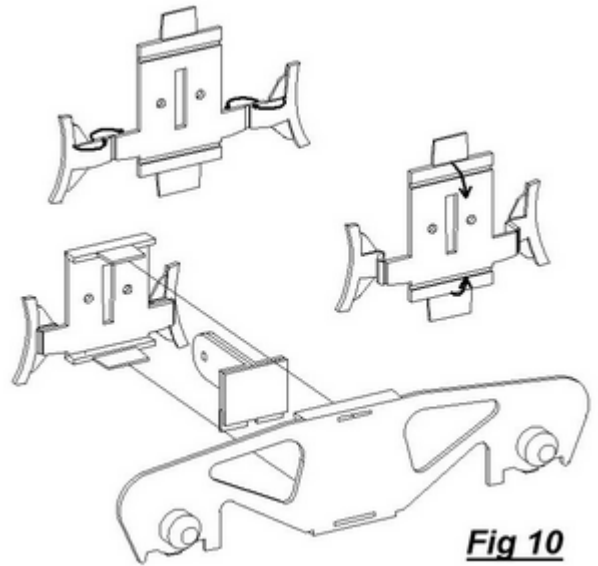

Fig 10

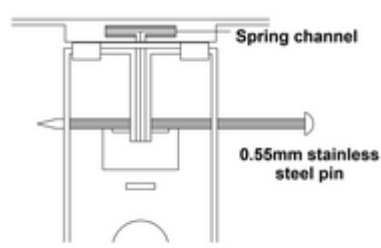

Fig 11

There remains the final check for freedom of movement before fitting the casting: insert the fulcrum slide of the assembled side-frame (the correct way up) into the slot in the end of the bolster and press fully home. This is a deliberate tight fit, but will ease after the first insertion; the outer faces on the ends of the legs can be tapered very slightly to assist the initial entry into the slot.

Temporarily secure with a 0.55mm stainless steel pin inserted through the hole in one side of the bolster box, and through the inner flaps and the fulcrum slide; a twisting action helps to get it through all the holes (Fig 11). Test that the side frames move freely up and down in the slots (when lifted, they should just about fall back down the slot under their own weight). If they are a little tight, gently compress the two inner flaps against the T leg of the fulcrum pin to ensure that

they are all square to the bolster face. Gently, but firmly, tension the side-frame away from the bolster, so that the fulcrum T is hard against the retaining pin.

If it is still tight, remove the retaining stainless steel pin and the side-frame assembly from the bolster, and **very carefully** open up the hole **in the fulcrum pin**, from both sides, with a small broach. Do this in very small stages, testing for freedom of movement as above, until the desired result is achieved. It should be necessary to open up a maximum of 0.05mm (i.e. the internal cusp from the etching process) to achieve the desired result. The aim is to get the freedom without generating any unnecessary sloppiness. Excessive clearances will allow "lozenging" of the side frames. Repeat for each of the sides. Strictly, each side should be matched to a specific bolster end, but in practise, this has not been found to be necessary. Nevertheless, take this into account at the final assembly; you may have to make further **very small** adjustments to the fulcrum hole on a "sticking" side member.

The cosmetic side frames can now be fitted on the outside faces of the etched brass frames. Depending on the method used, these may be secured by with solder (preferred), or Contact Adhesive.

The centrifugal casting process is subject to variation in shrinkage. Consequently it may necessary to increase the diameter of the rear bearing holes with a 2.2mm or 3/32"  $\varnothing$  mm drill in a pin chuck before they will fit without force. Also remove any residual flash with a scalpel to generate a clean casting.

The castings locate on to the bearings on the etched side-frames, and should be secured with 145<sup>0</sup> solder using a temperature controlled iron (Pewter melts at approx. 200<sup>0</sup>) Note that there may be a very slight bow in the casting, which is perfectly in order. Remove the side-frames from the bolster, and hold the casting firmly in position (finger pressure with a pad of tissue as insulator), and when satisfactorily aligned, apply flux and solder to laminate in the positions shown in Fig 12. **Do not apply solder near the outer ends, or you will fill the recesses in the back face, which represent the open ends on the real castings.** Wash thoroughly in very hot water and soak to ensure any flux within the laminate is removed. Rinse in very hot water, and allow to dry. Finally clean up the laminate joints with a fine flat needle file or small emery stick; the outer ends of the castings are slightly smaller than the etched side-frame, and this finishing will align the two parts of the laminate.

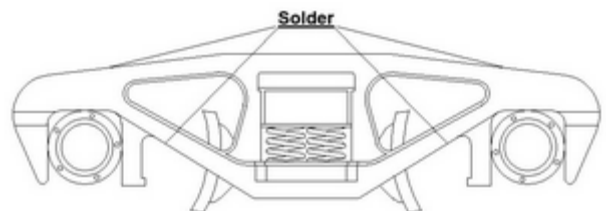

Fig 12

The alignment of the bogie side-frames must now be checked and adjusted, if necessary. This is important for the operation of the bogie springing, and to minimise end float on the axles.

Locate the two side-frames in position on the bolster, without any securing wire through the fulcrum pins, and place a pair of wheel-sets in position between the bearings – one side-frame can be partially withdrawn from the bolster to facilitate this. Gently hold the loosely assembled bogie, across the side frames, on a level surface; there should be just discernible side-play on the wheel sets. If there isn't any side-play, the ends of the axles will hold the side-frames clear of the bolster, and the side-frames will not "grip" the ends of the bolster. This can be corrected by gently, but firmly, easing the ends of side-frames outwards, with smooth faced pliers, while firmly holding the assembly across the bolster. The adjustments should be very small, and it is important not to overdo it and create too much side play. It is recommended that you keep components together, once these adjustments have been made.

The bogie components are now ready to be “finished”, but you can complete the assembly for testing, and then dismantled again for painting. As new, the bogies were painted black, but in service they quickly became covered in brake dust and wear products from the wheel - track contact (Matt mid brown colour – underframe dirt). Originally the axle boxes were yellow in BR days.

If you wish you can use brass blacking as a base before painting, **but do not allow this, or paint, to get anywhere near the rocking plate or the fulcrum pin.** Use suitable masking if spray painting. Similarly the outside rubbing face of the bolster should be kept clean, but, unlike the fulcrum pin, this can be easily polished with 600 grit wet & dry prior to assembly.

### 5. Fitting springs to side-frames:

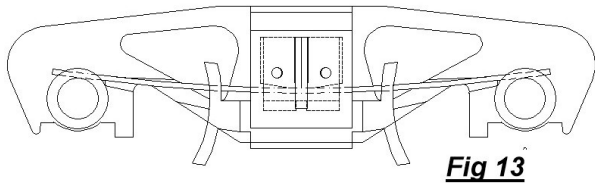

**Fig 13**

Take a 24.0 +/- 0.4mm mm length of chosen spring wire, (The length is fairly critical, and the cut ends must be free of burrs) and feed it through under the fulcrum pin channel, and across to sit in the slot above the pin point bearing. Lift the other end up, engaging the wire in the fulcrum spring channel (It should do this naturally), and push it over the top of the other bearing and into the slot. Finally check that it is seated correctly at both ends over the pinpoint bearings, and that it is working satisfactorily (Fig 13). Repeat for the other side. Apply a drop of light oil to the spring wire where it

sits on top of the wheel bearings, and into each of the pin-point bearing holes, ready for the wheel-sets.

Depending on the weight of your wagon, the thickness of the spring wire (Guitar strings) should be chosen to allow at least 75% available deflection under load. Typically:

- For a wagon wt of 72-80g use 0.009"
- For a wagon wt of 90-100g use 0.0095"
- For a wagon wt of 110-120g use 0.010" (supplied)

### 6. Final Assembly.

Locate one side-frame on the bolster, and secure in position with a 0.55mm stainless steel pin through the fulcrum pin. Push the pin through, so that the head is against the side of the bolster (Fig 14). Slide a short length (2-3mm) of pvc sleeving with care over the pointed end of the pin, and slide up the exposed end to hold the pin in position.

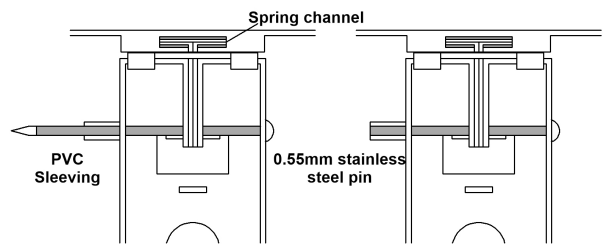

**Fig 14**

Locate the other side frame on the bolster, and position a 5.5 mm stainless steel pin through the bolster, but not yet through the fulcrum pin. Gently withdraw the side-frame enough to locate the two wheel-sets in position; locate one wheel-set first, and hold this in place whilst positioning the second wheel-set, and pushing the side-frame home. Secure the second side-frame by pushing the second 0.55mm pin through the fulcrum pin, and out the other side of the bolster. This method of installing the wheel-sets eliminates any distortion to the side-frames, important for minimising axle end float.

Check that the suspension is functioning correctly by applying finger pressure to the top of the bolster. When all is satisfactory, the second pin can be sleeved, and finally the excess pin **carefully** trimmed – Use eye protection when performing this task. The fulcrum pin securing pins can still work loose, and should both be secured to the bolster with a drop of cyanoacrylate at each end; this allows the bond to be broken easily, should you need to dismantle the bogie at a later date.

### Fitting to a wagon under-frame:

The method of fitting to the wagon under-frame will vary considerably, dependent on the basic construction.

Pivot bushes, 2mm set screws, and 2mm nuts are provided (Fig 15) Check that the pivot bush step sits inside the boss on the top of the bolster; Ease with a round needle file, or the tail of a small file if necessary.

For an etched brass under-frame the nut can be soldered in position, but the positioning is critical to give the required ride height

For plastic wagons the nut can be secured (Press fit) in a small off-cut and retained with a thinner laminate over the top (Fig 16). This can then be glued on to the pivot boss. The height can easily be adjusted by the choice of material thickness.

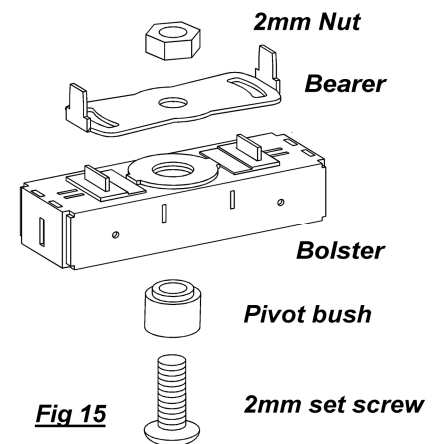

**Fig 15**



**Fig 16**

The rotation resist bearer is held between the pivot bush and retained nut. Cyanoacrylate can be used to hold in position and prevent rotation.